

TimberPro TL755C



Featuring...

- Cummins QSC8.3 - 330HP (243 kW)
- Auto-Reversing Fan
- IQAN MD4 7" Touch Screen control system
- Energy Recovering Hydrostatic Swing System with 76,700 ft-lbs of Torque
- Dedicated Dual Hydrostatic Drive System with 108,745 ft-lbs of Tractive Effort
- Best in Class Serviceability

The TimberPro TL755C is the second largest of the C-Series purpose built track machines. Designed exclusively for the forest industry the TL755C was built to handle extreme terrain and severe climates.

The undercarriage of the TL755C has long heavy duty track frames and a wide stance making it extremely robust and very stable.

Equipped with a powerful Cummins QSC8.3L engine, a technologically advanced IQAN MD4 touch screen control system, Parker L90-K220 Control Valve, a dedicated Rexroth hydrostatic swing system and dual Rexroth hydrostatic drive systems the TL755C is the perfect balance of power, performance and productivity



TimberPro Inc.
1407 Industrial Dr.
Shawano WI 54166 USA
Tel: 715-524-7899
E-Mail: info@timberpro.com
www.timberpro.com

TL755C

TimberPro Inc reserves the right to change specifications without notice or obligation. Product illustrations may be equipped with non-standard equipment.

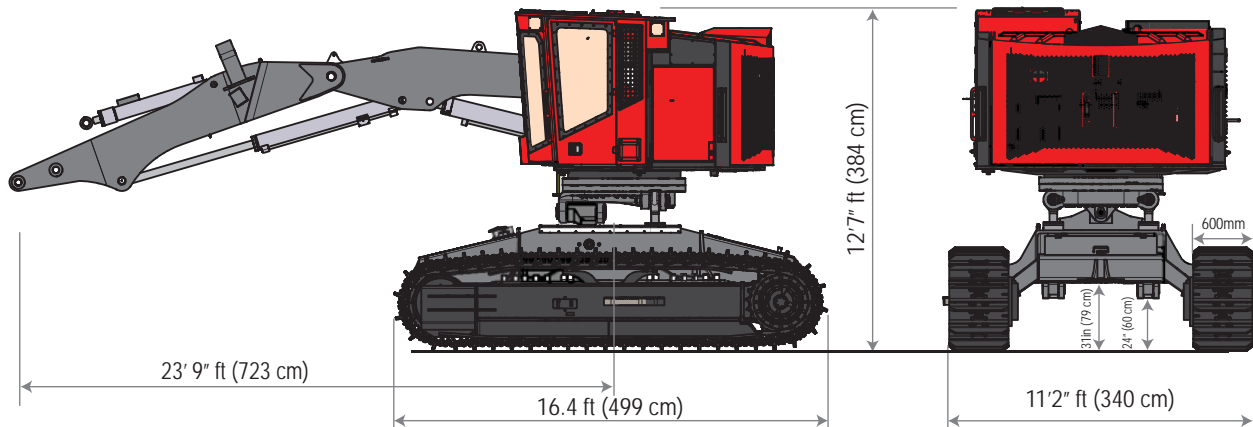

Engine:

Cummins QSC 8.3L
Max HP - 330HP (243 kW) @1800 RPM
Peak Torque - 1020 ft-lbs (1,383 N.m)
Fuel Tank - 250 gallons (946 Liters)

Cooling:

Fan - 44" Hydraulic Driven, Variable Speed with Auto Reversing Feature

Control System:

IQAN MD4 HD control system

- 7" touch screen
- Engine Management
- Troubleshooting Diagnostics
- Over and Under Temperature Protection

Electrical System:

Alternator - 100 amp 24 Volt
Batteries - 2 /12 Volt @ 1000 CCA
Work Lights - LED High Intensity Lighting

Serviceability:

Rear Gull Wing Canopy Opens to Access to Engine and Hydraulic Components
Hydraulic Tank Vacuum System

Safety:

ANSUL LVS Liquid Agent Fire Suppression System
Rear View Camera System

Hydraulic System:

Implement Pump - 145cc Variable Disp Piston
Swing Pump - Dedicated 90cc Hydrostatic
Track Drive - Dedicated 90cc Dual Hydrostatic
Disc Saw Pump - Dedicated 60cc Piston
Charge Pump - Gear Pump 50cc
Valve - Parker K220/L90LS
Electric hyd oil fill pump

Filtration System:

Charge Filter Non By-Pass 6 micron
Return Filters w/By-Pass 10 micron
Case Drain Filter w/By-Pass 10 micron

Upper Turntable Swing:

Gearbox - Rexroth GFB17 (32.47:1)
Bearing - Dual Ball / External Tooth
Swing Motor - Rexroth Bent Axis - 63cc Hydrostatic energy recovery system
Swing Speed - 6.8 RPM
Swing Torque - 76,700 ft-lbs
Continuous rotation swing

Leveling System:

Front - 28 Degrees
Rear - 7 Degrees
Side - 24 Degrees
One Button Control Auto-Leveling

Machine Weight:

Base Machine - 72,950 lbs (33,090 kg)
(approximate "woods ready" no attachment)

Boom Performance:

Feller Buncher - *Standard Stick Boom*
Lift Capacity @ Max Reach - 9,200 lbs (4,182 kg)
Maximum Reach (Pin Point) - 23.9' ft (7.23 m)
Feller Buncher - *Power Stick Boom*
Lift Capacity @ Max Reach - 10,580 lbs (4,800 kg)
Maximum Reach (Pin Point) - 22.9' ft (6.93 m)

Undercarriage:

Caterpillar 330 Frame w/345 Recoil Spring
Track Pitch - 8.5 Inch Pitch
Track Pads - 48 - D7G HD (600, 700 or 800mm)
Track Rollers - 9 (7 - Double and 2 - Single)
Final Drive - Rexroth GFT 8190 - 121.1:1 Ratio
Drive Motors - 170cc Auto Shift Rexroth
Tractive Effort - 108,745 lbs (484 kN)
Travel Speed - 0 to 3.5 mph
Counterweights *(optional)*

Operators Cabin:

ROPS/FOPS/OPS Certified cabin.
Three Emergency Escape routes
Fresh air filtered & Pressurized cabin
AM/FM/WB - Bluetooth radio - USB
Deluxe Seat - Air ride, Heat & Lumbar



TimberPro Inc.
1407 Industrial Dr.
Po Box 415
Shawano WI 54166 USA

Tel: 715-524-7899
Fax: 715-524-7898
E-Mail: info@timberpro.com
www.timberpro.com